

## CONNECTING THE SHARKCLEAN™ APP AND ROBOT

Please be sure to read the enclosed Shark® Owner's Guide prior to using your robot.

# Shark. AI ROBOT

## QUICK START GUIDE

### STEP 1 Create An Account

- Open the **SharkClean** app and set up your account.

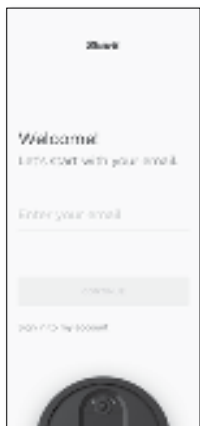

### STEP 2 Activate Robot Wi-Fi

- Hold down **Dock** and **Clean** buttons simultaneously until **Wi-Fi** light (📶) on robot blinks.



### STEP 3 Select Robot (Apple iOS Only)

- Exit the app and open Wi-Fi settings.
- **Select your robot** (Ex. Shark\_RVXXX) from the menu.
- Exit settings and return to the SharkClean app.



### STEP 4 Connect To Home Wi-Fi

- If you have multiple Wi-Fi networks, select the **2.4 GHz** network.



### STEP 5 Success!

- When pairing is complete, the **Success** screen will appear.

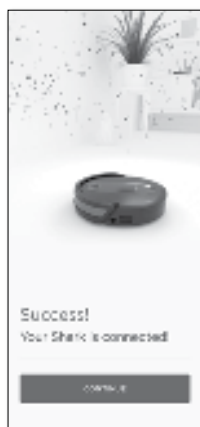

### WI-FI TROUBLESHOOTING

- To use the app, your phone must be connected to a 2.4GHz network. The app will not work on a 5GHz network.
- **DO NOT** use a VPN or a proxy server.
- Make sure Wi-Fi isolation is turned off on the router.

#### CAN'T CONNECT TO WI-FI?

##### Restart your phone Reboot your robot

- Press the power button on the side of the ROBOT to the OFF position for 10 seconds. Press it again to turn power back ON.

##### Reboot your router

- Unplug the router power cable for 30 seconds, then plug it back in. Allow several minutes for your router to reboot completely.

To stay current on our latest updates and features,  
**DOWNLOAD THE SHARKCLEAN™ APP.**

Search “SharkClean” in the app store.



Scan QR code with your phone's camera to quickly find and download the app

## SETUP

### STEP 1 PREP YOUR HOME

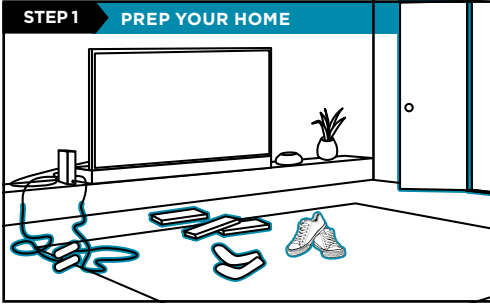

- Before cleaning, clear cords and remove small obstacles like clothing or toys that are less than 2.8" tall.
- Open interior doors in rooms you want your robot to clean.

### STEP 3 SET UP THE DOCK

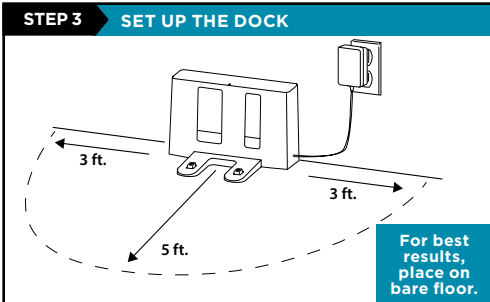

For best results, place on bare floor.

- Find a **permanent** location for the dock, as pictured above, in a central area with a strong Wi-Fi signal.
- Place the dock on bare floor, with its back against the wall.
- Plug in the dock. The **Indicator Light** will illuminate green when the dock has power.

### STEP 5 CHARGE THE ROBOT

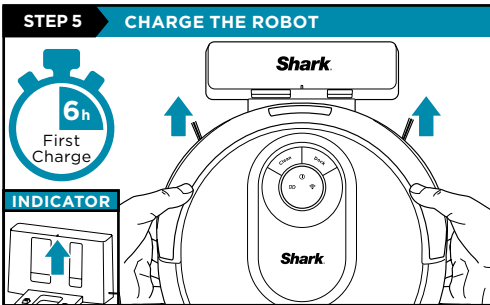

Place robot on dock to charge. The dock indicator light will turn **blue** and the robot will beep when charging begins.

### STEP 2 PREP THE ROBOT

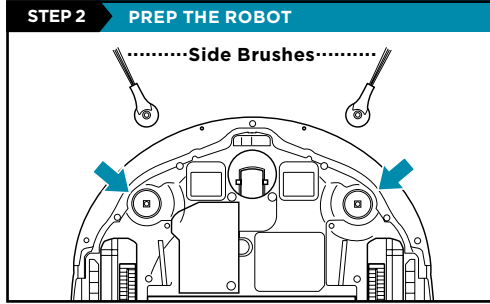

- Remove protective film from robot and dock.
- **Attach side brushes.**

### STEP 4 POWER ON ROBOT

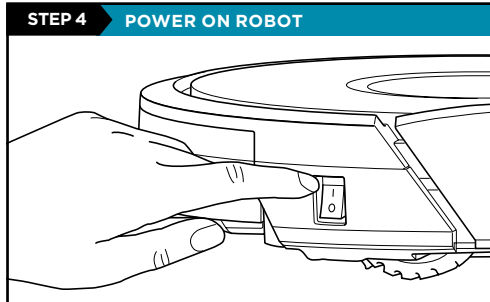

To charge, the **Power** button on the side of the robot must be in the ON position (I).

### STEP 6 DOWNLOAD THE APP

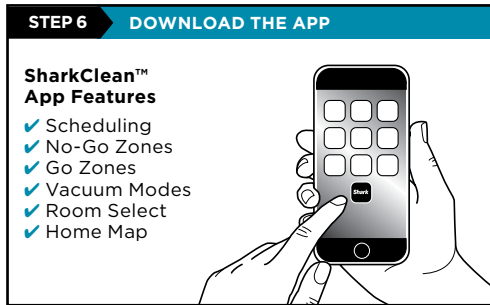

#### SharkClean™ App Features

- ✓ Scheduling
- ✓ No-Go Zones
- ✓ Go Zones
- ✓ Vacuum Modes
- ✓ Room Select
- ✓ Home Map

Scan QR code on front cover to download the SharkClean app.

**NOTE:** For more information on connecting your robot, see next page.

## STEPS FOR SUCCESS

Before your robot can vacuum, it must complete an **Explore Run** to map your home.

- This will take less time than a full vacuum run.
- After the Explore Run, there will be an interactive map of your home in the app, and your robot will be ready to clean.

After the explore run is complete, press the **Clean** button on the robot or in the app to send the robot on its first vacuuming run.

### EXPLORE RUN

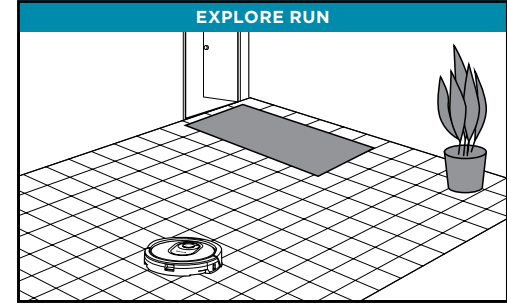

## LIVING WITH YOUR ROBOT

### INTERACTIVE MAP



After the Explore Run, the robot will create an interactive map in the app, where you can create rooms and no-go zones.

### DOORWAYS AND THRESHOLDS

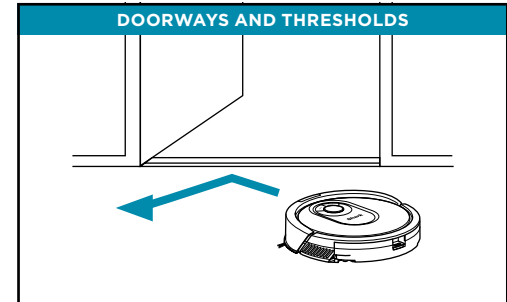

Your robot can easily climb over most thresholds, but if one is too high, set up a no-go zone in the app to block it off.

### AVOID MOVING THE ROBOT OR DOCK

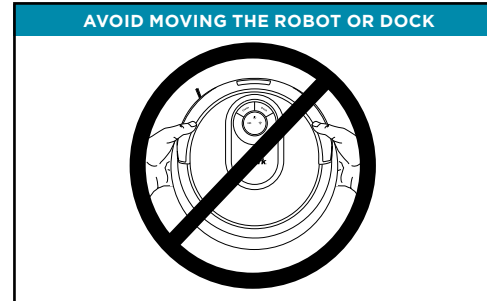

While your robot is cleaning, do not pick it up and move it, or move the charging dock—this will impact the robot's ability to map your home.

### EMPTYING THE DUST BIN

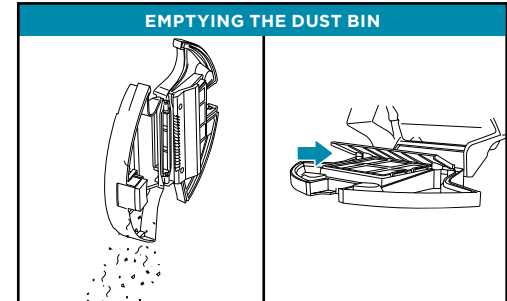

During the first few weeks of use, the dust bin will need to be emptied more frequently, as your robot will now be removing dust and debris from areas that were previously hard to reach. Empty debris and dust into trash.

Remove any debris between the filter and the plastic shield.

### Questions? Two Easy Steps If You're Stuck:

Having trouble connecting to your robot? Call **1-855-460-5425** for robot support. For how-to videos, FAQs, troubleshooting, and tips & tricks visit: [sharkclean.com/support](http://sharkclean.com/support)

### Smart Home Setup

To set up voice control using Google Home or Amazon Alexa, visit [sharkclean.com/app](http://sharkclean.com/app) for instructions.